

Features

- Transformerless 2-wire to 4-wire conversion
- Battery Feed
- Ringing & Messaging Facility
- Power Down with Wake Up output
- Automatic Ring Trip
- Programmable Constant Current
- Earth Ground Button detection
- Switch Hook detection
- Interface for a programmable CODEC
- Ring ground over-current protection
- Impedance reflection
- Loop Length Indication

Applications

Line Interface for

- PABX
- Intercoms
- Key Telephone Systems
- Control Systems

ISSUE 2

April 1995

Ordering Information

MH88614 30 Pin SIL Package

0°C to 70°C

Description

The SLIC provides a complete interface between an industry standard programmable CODEC or DSP and a subscriber loop.

Functions provided include battery feed, zero crossing ring control, programmable current feed, power down with wake up signal, cadenced messaging facility, switch hook & dial pulse detection, loop length indication and the capability of reflecting a programmable CODEC's impedance or supplying a standard 600 ohm impedance to the line. The device is fabricated as a thick film hybrid using various technologies for optimum circuit design high reliability.

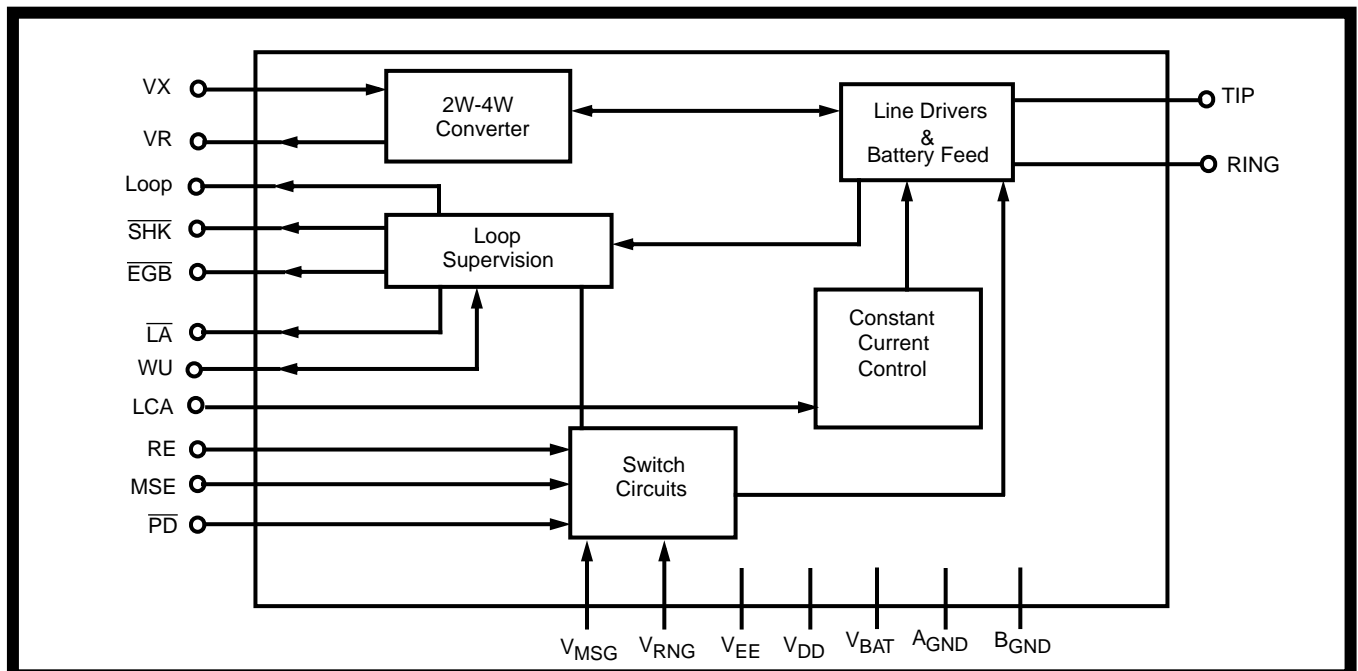

Figure 1 - Functional Block Diagram

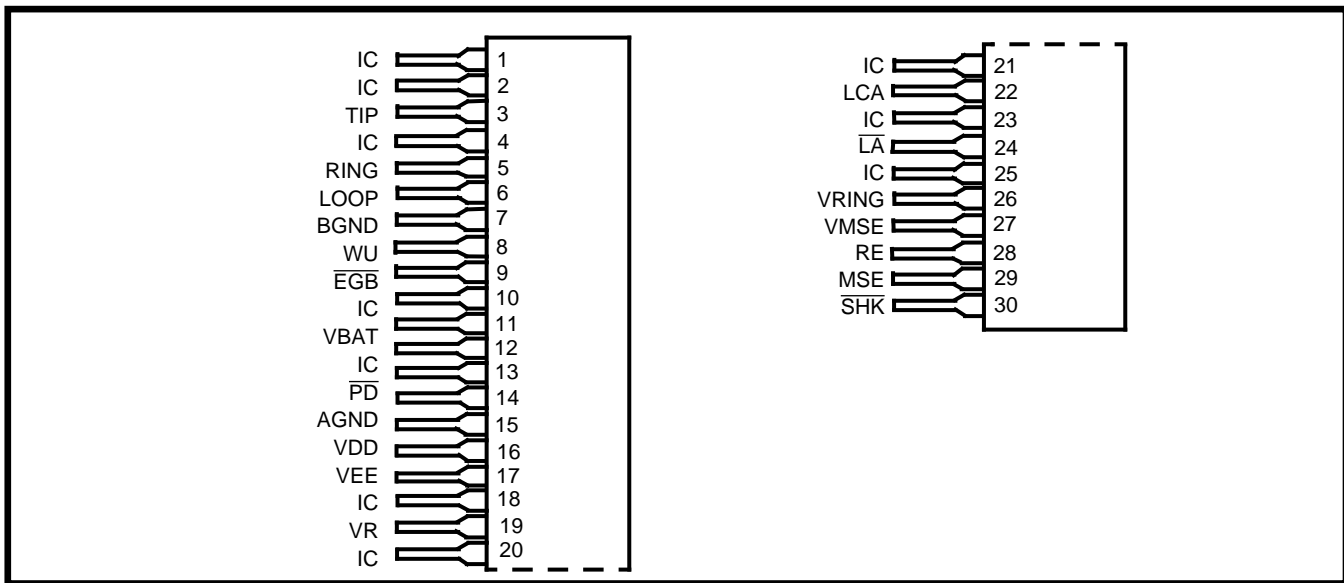

Figure 2 - Pin Connections

Pin Description

Pin #	Name	Description
1	IC	Internal Connection
2	IC	Internal Connection
3	TIP	Connects to the “Tip” lead of the telephone line.
4	IC	Internal Connection
5	RING	Connects to the “Ring” lead of the telephone line
6	LOOP	Loop Length Indication. The output on this pin is proportional to the loop length / resistance, and is valid for off hook conditions only.
7	BGND	Battery Ground. This pin is the return pin for the battery feed to the line and also for the message voltage supply and the Ring Voltage supply. This pin should normally be connected to AGND.
8	WU	Wake Up(Output). When in the power down mode this pin goes high to indicate the phone has gone off hook. When this occurs the power down signal should be removed.
9	$\overline{\text{EGB}}$	Earth Ground Button Detection (Output) This output goes low when the ring lead or tip lead is grounded.
10	IC	Internal Connection
11	VBAT	Battery Feed Supply. This pin is the supply for the line feed. (Typically -48V).
12	IC	Internal Connection
13	$\overline{\text{PD}}$	Power Down (Input) Applying a logic 0 (Active low) will Power down the hybrid. This may be used, but must be removed to allow a call to be made or to reduce power consumption.
14	AGND	Analog Ground. This pin is the return pin for the positive and negative supplies and is normally connected to BGND.
15	VDD	Positive Supply. (Typically +5V).
16	VEE	Negative Supply. (Typically -5V).
17	IC	Internal Connection
18	VR	Receive (Input). The audio input signal is applied to this pin from the programmable CODEC. This signal is internally a.c. coupled

Pin Description- (Continued)

Pin #	Name	Description
19	IC	Internal Connection
20	VX	Transmit (Output). The audio output signal appears on this pin and is internally a.c. coupled. This signal is applied to the programmable CODEC.
21	IC	Internal Connection
22	LCA	Loop Current Adjust (input). The circuit has two constant current settings that are logic selectable
23	IC	Internal Connection
24	$\overline{\text{LA}}$	Loop Alarm (Output) When the loop impedance exceeds the maximum limits that the SLIC can support for a specified voltage & current this output will go low. This indicates that the SLIC will no longer support the line. Note: This pin will also pulse low if Loop Disconnect Dialling is performed, and goes low when the phone is on hook.
25	IC	Internal Connection
26	VRING	Ring Voltage Supply. This pin is the supply for the Ringing signal to the telephone. (Typically 90V _{RMS} on -48V battery).
27	VMSE	Message Voltage Supply. This pin is the supply for the message signal to the telephone. (Typically -100V)
28	RE	Ring Enable (Input). The ringing signal is applied across Tip & Ring by applying a logic 1 to this pin while the phone is "On Hook". Ringing will be automatically stopped when the phone goes "Off Hook" regardless of the state of the RE pin.
29	MSE	Message Signal Enable (Input). A cadenced signal can be applied to this pin which will switch the V _{MSG} voltage onto Tip & Ring. The output voltage is internally conditioned to prevent bell tinkle on the telephone. This is automatically switched off when the phone goes off hook.
30	$\overline{\text{SHK}}$	Switch Hook (Output). The output of this pin goes low when the phone goes "Off Hook" and can be used externally to switch MSE off.

Functional Description

The MH88614 is an ONS SLIC for use with a programmable / intelligent CODEC or DSP. The SLIC performs all of the normal interface functions between the CODEC and the analog telephone set whilst having such additional features as Earth Ground Button Detection, message switching and Ringing switching with zero crossing.

The MH88614 is available as a 30 pin SIL package to increase board densities.

2 Wire to 4 Wire Conversion

The hybrid performs 2 wire to 4 wire conversion by taking the 4 wire signal from the programmable CODEC at VR and converting it to a 2 wire differential signal at Tip & Ring. The 2 wire signal applied across Tip & Ring by the phone is converted to 4 wire signal at Vx which is the output from the SLIC to the programmable CODEC. Both the VR input & Vx output are internally a.c. coupled.

Loop Supervision

The Loop Supervision circuit monitors the state of the phone line and provides three different output stages.

When the phone goes "Off Hook" the $\overline{\text{SHK}}$ pin goes low to indicate this state. This pin reverts to a high state when the phone goes back "On Hook" (see figure 3).

When the phone is off hook the circuitry can also detect two other features of the line status namely Earth Ground Button & Loop Alarm.

A logic low signal on the Earth Ground Button output indicates that an earth ground path has been applied to the Tip or Ring lead of the telephone. This function can be used for recall operations on phone sets with Earth Ground Buttons.

The Loop Alarm signal low to indicate that the R_{Loop} has been exceeded and that the circuit will no longer support the line.

The hybrid also provides an output which is proportional to the loop length / resistance. \overline{LA} must be high for I_{Loop} to be valid.

$$R_{Loop} = \frac{[(10 \times V_{Loop}) - 1.5]}{I_{Loop}} - 82\Omega$$

Where V_{Loop} = the voltage at Loop
 I_{Loop} = the programmed line current

Constant Current Control

Whilst working within the R_{Loop} maximum limit set by the I_{Loop} & V_{Bat} levels chosen the circuit allows the loop current to be set to one of the two discrete levels by the use of the loop current adjust pin. Applying a logic low to this pin sets the constant current to the lowest level. By changing the level to a logic high the constant current is set to the highest level. This feature can be used with the loop alarm signal when setting up the line to chose the loop current setting most suitable.

Line Drivers & Battery Feed

The Line Drivers & Battery Feed circuit provide power to the line and allow bi-directional audio transmission.

The line impedance present by the line driver circuitry is a nominal 600 ohms, allowing the circuit to be used on its own in a PABX application. The nominal impedance can be modified to look like a complex impedance such as those used within

Europe by allowing an impedance to be reflected through the SLIC from the CODEC or DSP module.

The outputs at tip & ring protected from short term over voltage between tip & gnd, ring to gnd or tip to ring reducing the requirement for secondary protection circuitry.

There is also long term protection on the outputs against short circuits applied across tip & ring, tip to gnd, ring to gnd and tip & ring to gnd.

Switch circuits

There are three switches built into the functionality of this circuit, they are Ringing Enable, Message Signal Enable and Power Denial.

Ringing Enable allows a logic level to be applied to a pin and the ringing voltage superimposed on a d.c. level to then be switched onto the line. The ringing signal applied to the line at zero voltage crossing and switched off at zero current. (see figure 3). The ringing signal can be terminated by either returning the Ringing Enable pin to a logic low level or it will automatically stop when the phone goes off hook regardless of the state of the input pin.

The Message Signal Enable pin provides the switching control of the message voltage. A logic high on the MSE pin applies the message voltage to the line. Internal circuitry allows the input signal to MSE to be cadenced, causing the output signal to be cadenced, without causing bell tinkle. This is possible by conditioning the rising and falling edges of the output signal. Message Signal Enable also has auto trip facility.

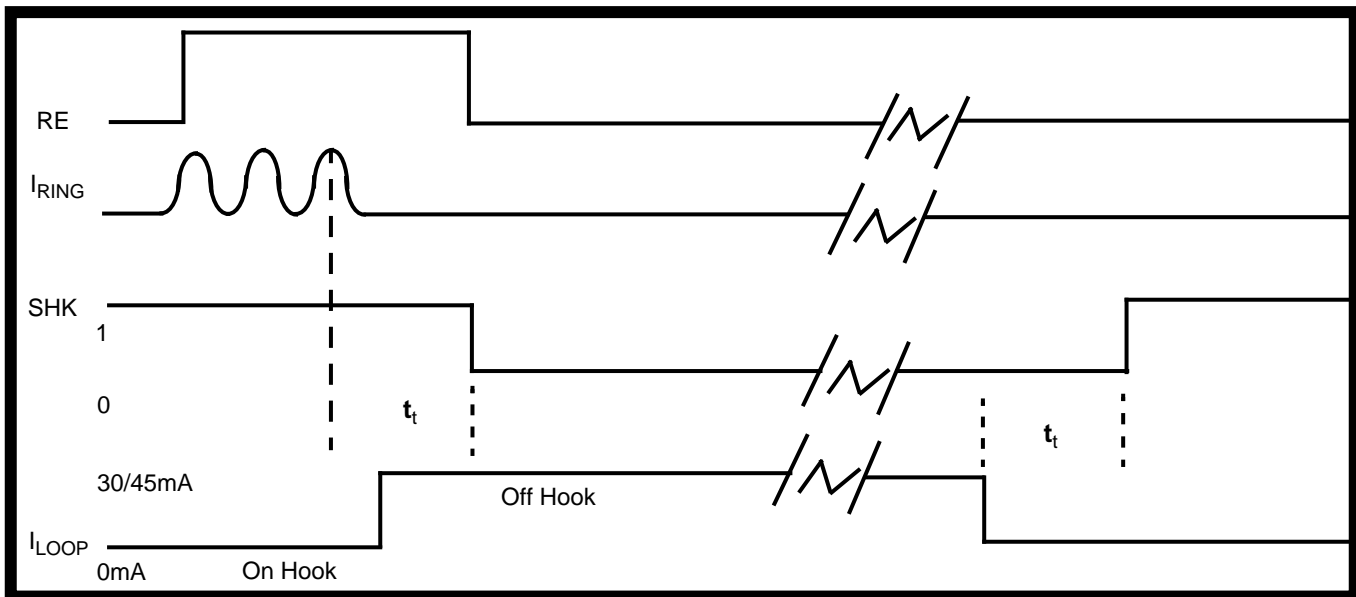

Figure 3 - Call Supervision

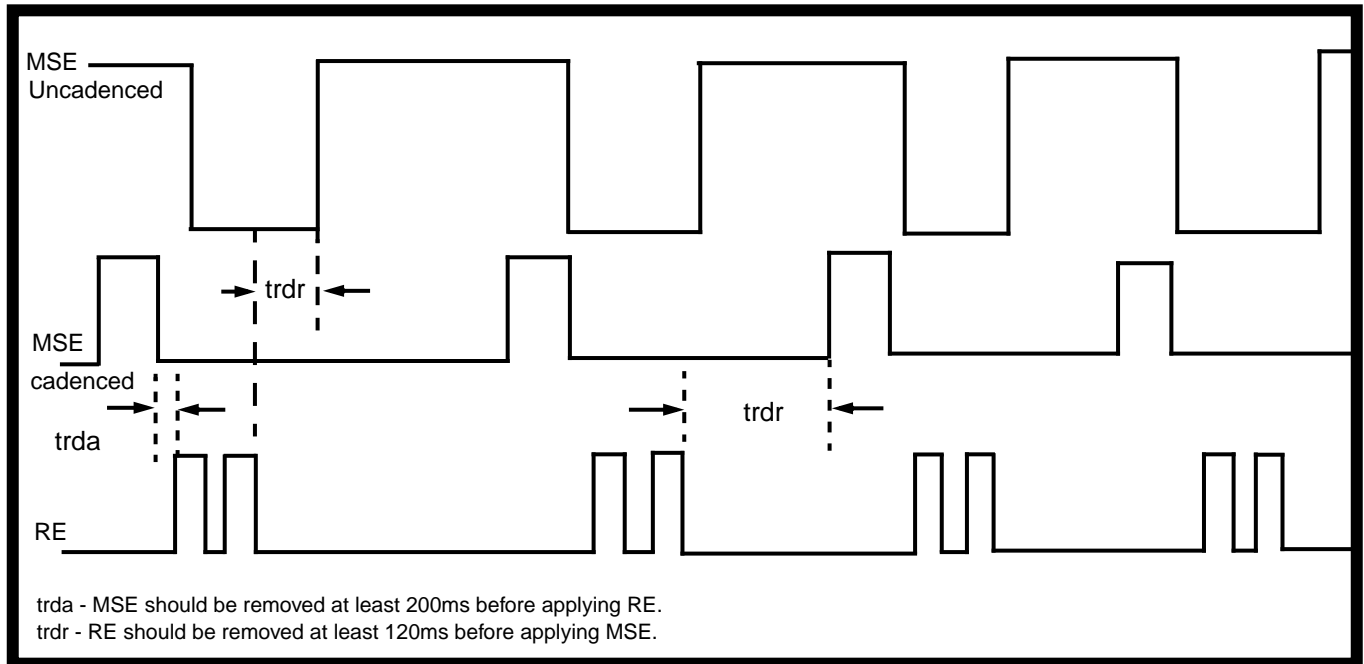

Figure 4 - Call & Message Indication

When applying ringing and message signal to the phone the two signals should be applied separately to minimise total power consumption. Figure 4 indicates how the timing of this process could best be achieved for cadenced and uncadenced message signalling.

Power Denial can be applied at any time to remove the line from service. The Power Denial input enables the line to be isolated from the battery under fault conditions or for maintenance purposes. A logic low will remove the battery feed whilst a logic high will provide power to the line.

Absolute Maximum Ratings*

	Parameter	Symbol	Min	Max	Units	Comments
1	DC Supply Voltage	V_{DD}	-0.3	+15	V	
		V_{EE}	+0.3	-15	V	
		V_{BAT}	0.3	-60	V	
2	Ringing Voltage	V_{RING}		130	V_{RMS}	
3	Message Voltage	V_{MSG}		-180	V	$V_{DC} + AC_{PEAK}$
4	Overvoltage Tip/Gnd Ring/Gnd, Tip/Ring			300	V	MAX 1ms (with power on)
5	Ringing Current	I_{RING}		45	mA	
6	Message Current	I_{MSG}		6	mA	
7	Short Circuit current (continuous), Tip/Gnd, Ring/Gnd, Tip/Ring			60	mA	
8	Storage Temp	T_{STG}	-40	+100	°C	
9	Package Power Dissipation	P_{DISS}		2.5	W	T_{AMB} 70°C max

* Exceeding these values may cause permanent damage. Functional operation under these conditions is not implied.

Recommended Operating Conditions

	Characteristics	Sym	Min	Typ*	Max	Units	Comments
1	Operating Supply Voltage	V_{DD} V_{EE} V_{Bat}	4.75 -4.75 -22	5.00 -5.00 -48	5.25 -5.25 -60	V V V	
2	Ringing Voltage	V_{RING}	50	90	100	V_{RMS}	17 to 55 Hz on a DC bias of -22V to -60V
3	Message Voltage	V_{MSG}		-100	-130	V	$V_{DC} + AC_{PEAK}$
4	Operating Temperature	T_O	0	25	70	°C	$V_{Bat} I_{Loop}$ -48V 45mA

* Typical figures are at 25°C with nominal $\pm 5V$ supplies and are for design aid only: not guaranteed and not subject to production testing.

DC Electrical Characteristics - Voltages are with respect to GNDA unless otherwise stated.

	Characteristics	Sym	Min	Typ*	Max	Units	Test Conditions
1	Supply Current	I_{DD} I_{EE} I_{Bat}		10 10 10	15 15 60	mA mA mA	$\overline{PD} = \text{High}$
2	Power Consumption	P_C		300 1800 50	400	mW mW mW	Standby, $V_{Bat} = -48V$ LCA = Low, (Off Hook) $\overline{PD} = \text{Low}$
3	Constant Current Line Feed		25 40	30 45	35 50	mA mA	LCA=Low LCA=High
4	Operating Loop (Inclusive of Tele. Set)	R_{Loop}			750 1150 400	Ω Ω Ω	$I_{Loop} = 45mA$ $I_{Loop} = 30mA$ $V_{BAT} = -48V$ $I_{Loop} = 30mA$ $V_{BAT} = -22V$
5	Off Hook Detection Threshold	\overline{SHK}		10		mA	
6	Unbalanced Detection	\overline{EGB}		10		mA	
7	V_{MSG} Leakage Current			2	200	μA	MSE = LOW
8	V_{MSG} Bias Current				1.5	mA	MSE = HIGH♣ $V_{MSG} = -100V$
9	V_{MSG} Voltage Drop			4	5	V	$I_{MSG} = 3mA$
10	LCA, MSE, RE, \overline{PD} Input Low Voltage Input High Voltage	V_{IL} V_{IH}	2.0	0.4 2.4	0.8	V V	$I_{il} = -2mA$ $I_{ih} = 0.4mA$
11	\overline{EGB} , \overline{SHK} , \overline{LA} , WU Output Low Voltage Output High Voltage	V_{OL} V_{OH}	2.4		0.4	V V	$I_{ol} = 2mA$ $I_{oh} = -0.4mA$
12	Loop Output Voltage	V_{Loop}	0		-5	V	$\overline{PD} = \text{High}$ $\overline{SHK} = \text{Low (Off Hook)}$ $V_{Bat} = -48V$

* Typical figures are at 25°C with nominal $\pm 5V$ supplies and are for design aid only: not guaranteed and not subject to production testing.

♣ Averaged level with no load applied, and a cadence of 1s "On", 3s "Off".

AC Electrical Characteristics

	Characteristics	Sym	Min	Typ*	Max	Units	Test Conditions
1	Auto Ring Trip/Message Trip Detect Time	tt		100	150	ms	$V_{BAT} .48V$
2	Impedance (2W)	Z_{in}		600		Ω	No External Feedback ♣
3	Return Loss (2W)	RL	22	30		dB	♣
4	Transhybrid Loss	THL	18	20		dB	♣
5	Impedance at VR			100k		Ω	AC coupled via 0.1 μ F
6	Impedance at VX			10		Ω	AC coupled via 0.1 μ F
7	Gain VR to 2W @ 1kHz		-0.3	0	0.3	dB	Z_{TERM} @ 2W = 600 Ω Z_{SOURCE} @ VR < 10 Ω
8	Gain Relative to 1kHz			± 0.3		dB	300-3400Hz
9	Gain 2W to VX @ 1kHz		-0.3	0	0.3	dB	Z_{SOURCE} @ 2W = 600 Ω Z_{LOAD} @ VR > 100k
10	Gain Relative to 1KHz			± 0.3		dB	300-3400Hz
11	Longitudinal to Metallic Balance at 2W	LCL	48	56		dB	300-3400Hz
12	Harmonic Distortion @ VX and 2W	THD		0.1	1	%	0.1Vrms @ 1kHz
13	Max. Signal Level @ VX and 2W			1.1		Vrms	1kHz THD \leq 10%
14	Common Mode Rejection Ratio @ 2W	CMRR	40	50		dB	0.5Vrms @ 1kHz
15	Idle Channel Noise @ 2W @ VX	Nc			12 15	dBrc dBrc	CMess. Filter CMess. Filter
16	Power Supply Rejection 2W and VX	PSRR V_{DD} V_{EE} V_{BAT}	25 25 25	35 35 40		dB dB dB	0.3Vp-p @ 1kHz
17	V_{RING} Voltage Drop			4	5	Vrms	$I_{RNG} = 10mA_{RMS}$

* Typical figures are at 25°C with nominal $\pm 5V$ supplies and are for design aid only; not guaranteed and not subject to production testing.

♣ The 2W impedance and THL are modified to the required value by external feedback applied by the programmable codec to the hybrid where required. Values quoted are for the hybrid on its own with no external feedback. Ref. 600 Ω , 300Hz to 3400Hz

Applications

This SLIC has been designed to be used with minimal external components in applications where programmable CODEC's or DSP's are used.

Figures 5& 6 show a typical application where the MH88614 is connected to a programmable CODEC and a phone.

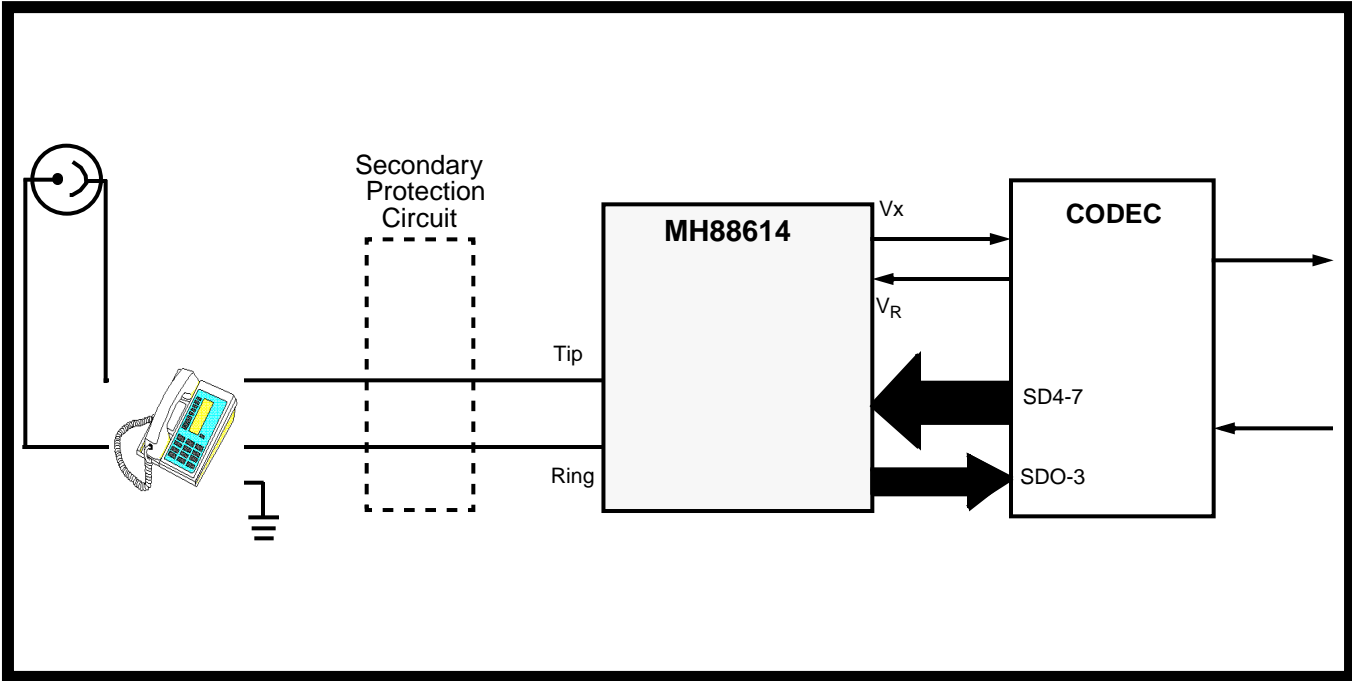

Figure 5 - Typical System Application

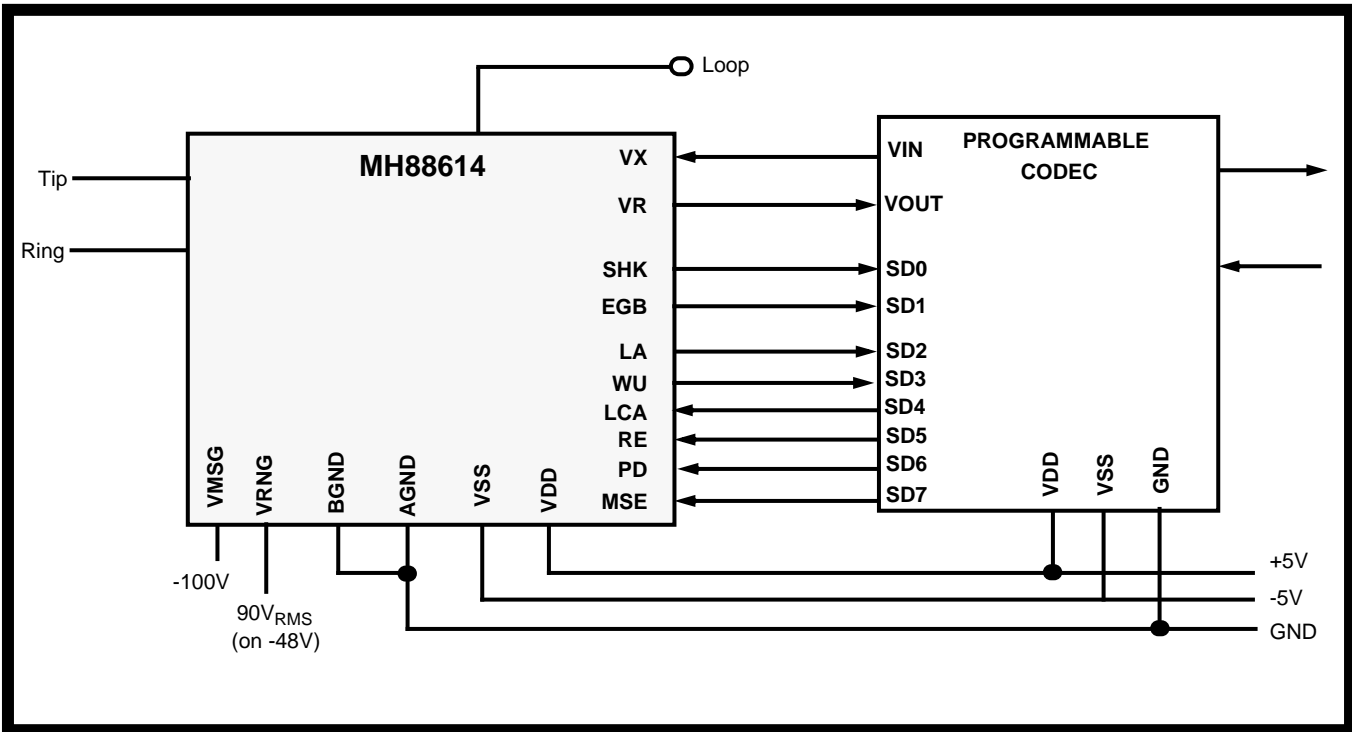

Figure 6 - Interconnection Diagram

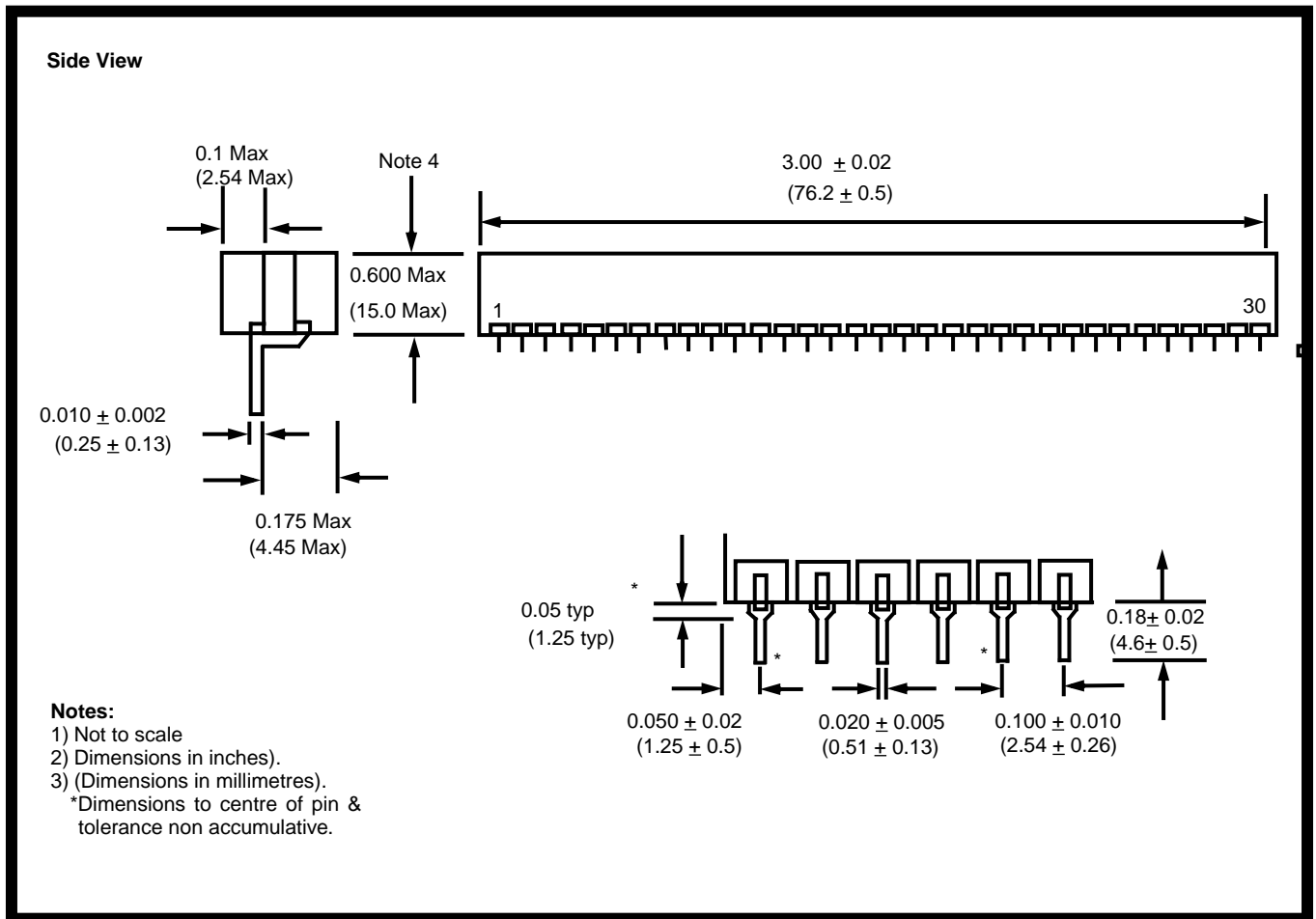

Figure 7- Mechanical Diagram

Notes: